



Created for well-being

Welcome to UNIC, the treatment centre that enhances the whole dental experience.

Our aim with UNIC is to introduce something familiar and homely into the dental surgery.

Our intention is to create a pleasant and relaxed environment for both the patient and dentist.

The unit is able to accommodate the person relaxing in the chair as well as facilitate the work going on around the patient. The human element is carefully considered throughout the process

- from the patient to the dentist and dental assistant, even to the service engineer.

Thomas Steen Nielsen, heka dental



For some people the annual visit to the dentist is simple - nothing more than a routine check-up by another doctor.

For others - for example, my daughter-in-law - it is actually associated with a pleasant feeling. She looks forward to it each time she gets her teeth checked and polished. She feels 'cleansed' afterwards. It is a "wellness" treatment for her teeth and mouth.

However, many experience the yearly visit to the dentist as a cause for great discomfort, maybe anxiety or, to put it bluntly, dental phobia.

It is these people we had in mind when we created the design for UNIC.

'Art is not appearing to be, but being'

Another important challenge, when you work on a design for dentists, is that it is situation-specific work.

In fact, the situation is always the same: the dentist sits on their chair and does not actually move very much. Meanwhile the dental assistant runs around fetching and carrying, writing and doing things.

Maybe this is one of the reasons why the prospect of a visit to the dentist's chair is so alienating for some, and a cause for unease. There you lie, a little person in the midst of so much technical equipment.

You begin to feel as though you are almost becoming a part of the machinery, with the suction hose stuck in the corner of your mouth and the drill boring into your teeth.

Consequently, it is important everything should be within easy reach for the dentist and dental assistant: the instrument table, the instruments, trays, light, x-ray unit etc.

One of the most important goals we had for the treatment centre, which you see here, is that it should be humanised. Or at least more humanised than previously. It is a concept that can be seen reflected in the sweeping, organic shapes, the curved surface, the s-shaped top and the stylish furnishings of the unit.

We have tried to eliminate the rigid, clinical look as much as possible.

David Lewis, Designer



Designed by David Lewis

The internationally renowned designer, David Lewis, who has worked together with heka dental since 2003, is recognised for always adopting an open-minded starting point in each individual project and not being ruled by an inflexible design philosophy. This fundamental approach to creating beautiful, functional designs has, among other reasons, made David Lewis world-famous for his striking designs for Bang & Olufsen, Vestfrost, Elica og Scholtès etc.



From the vision to the product

It started with a vision, which was transformed into thousands of line drawings. After that there followed numerous prototypes before the final design fulfilled all our demands for the ultimate treatment centre.

As with all good designs, the aim is to combine aesthetics with functionality. Our goal with UNIC is to deliver a unit that, because of its inviting appearance and carefully thought through functionality, will create the perfect environment for a pleasant visit to the dentist.



The long road to success

The starting point for creating a successful functional design is to listen to the people who will use the product.

All the people who will come into contact with UNIC - patients, dentists, dental technicians and service engineers - have assessed more than 2,000 major and minor details.

We have modified UNIC's design according to the input we have received from them. Then we have asked our testers to assess the unit again.

We have been through this process again and again because we know it is the small details that count.



Focus on detail

It is the smallest of details that define a good or bad design, and we have paid great attention to every single detail in UNIC because we believe that our customers should be happy with the product for many years to come.

As an example, take the rear door of UNIC which is made out of stainless steel. In the finishing process each individual component is polished in the correct direction, so that when the pieces are assembled all the polished surfaces are facing the same direction. It is more expensive. It is also more difficult, but we believe that is absolutely necessary to complete the overall quality.

Some may think that it is a waste of time to use resources on such details. Others are delighted that we go to such lengths to achieve perfection.





Designed for well-being

UNIC ensures optimal contact between the dentist and patient. With all the instruments at hand, the dentist can work effectively and continuously without losing contact with the patient. This creates a calm working atmosphere which is reassuring and relaxing to the patient.

With UNIC we have created a piece of furniture, in which each design feature is aimed at inspiring confidence and well-being in the patient.



Lightweight

UNIC is proof that a treatment centre need not be heavy or clumsy.

The entire UNIC treatment centre appears to be hovering in space. By using many varied techniques, we have been able to accentuate the unit's lightness and simplicity - for example, the instrument table and trays are supported centrally by means of a swivel joint, and the hoses never touch the ground.

Similarly, by creating symmetry in the shapes, we have given the unit aesthetic lines. For example, the circular arrangement of the instruments mimics that of the rinsing bowl - and the shape of the handle on the instrument table is echoed in the glass holder.







360° design

We chose a polished stainless steel finish for the UNIC floor cabinet and rear door. One of the unique qualities of polished stainless steel is that it reflects its surroundings.

This means that UNIC takes on the colour of its surroundings, wherever it might stand.

Minimalist on the surface Functional and flexible beneath

On UNIC we have deliberately hidden away all that does not need to be visible. The instrument table is effectively minimalist without any superfluous techno-paraphernalia or unnecessary gadgets.

This gives you the sense that UNIC is a piece of furniture rather than just a piece of equipment.

UNIC - Quintessentially Simple.



Designed in perfect balance

The UNIC's arm hides the cables, water and air lines behind its light, but hard wearing surface of anodized aluminium.

The big joints move with precision in every direction, despite the various strains they come under from the instrument table, monitor, x-ray unit and light.

The result is an arm with optimal balance.





Simple technology
creates a simple
working procedure



The instrument table's handle is fully integrated with UNIC's display and touch pads. It is easy to find by both eye and hand - even when your attention is elsewhere.

With a light touch on the cuspidor touch pad, the suction stops, the operating light goes off and the patient's chair adjusts to the rinsing position. Meanwhile the glass fills with water.

By touching the cuspidor touch pad again, the patient's chair returns to its previous working position.





From Solo to Duo - in under 2 seconds

Flexibility creates job satisfaction. This is why we have ensured that UNIC can adapt to its varied and complex tasks - easily and smoothly.

The assistant's unit is designed with a telescopic arm that can be adjusted from two to four-handed treatment in seconds.



Comfortable Chair

A relaxed patient creates ideal working conditions for the dentist. For this reason we have created a treatment centre that is comfortable for both the patient and dentist. It is a dream to sit on, whilst the dentist has the ideal working conditions, regardless of whether they are standing or sitting.

The feel of the patient's chair, and the choice of materials and colours complement UNIC's clear, clean lines and simple design. At the same time we have remained focused on the functionality of the chair and in particular its easy adjustment by means of a foot pedal or the electronic control panel on the instrument table.



The Right Mood

Imagine that you are sitting alone and looking out over the sea. Before long your thoughts float away, and you experience an inner calm that spreads through your body. It is exactly this mood that we have tried to create.

UNIC gives the patient the chance to relax, while the dentist and assistant work calmly and effectively.





1]

28



2]



3]

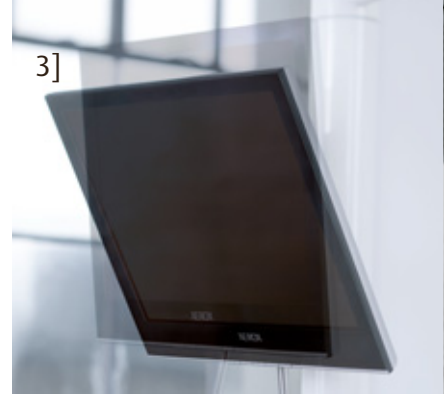

2]



1] On the balanced spring model each instrument is perfectly balanced and the extra long silicon hoses ensure ergonomically correct working postures.

2] UNIC can be mounted with a single tray, double tray and/or X-ray monitor.

3] UNIC multimedia with monitor for patient-friendly displaying of intraoral photos, videos, digital x-ray or other IT-media.

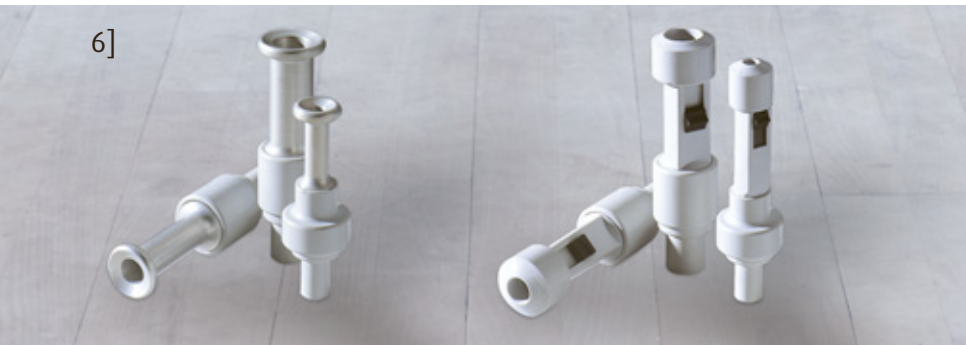

4] The unique patented round foot control can be activated from any direction with either the right or left foot, releasing you from any fixed working posture.

5] UNIC can also be delivered with a variable foot control.

6] UNIC is delivered with either adjustable suction valves or hygienic aluminium suction valves.

7] The instrument support can be removed easily for cleaning.

8] To ensure the supply of fresh water, UNIC can be delivered with an automatic water rinsing system for the instruments.

9] UNIC is available with a unique automatic suction hose cleaning system,

which is activated by simply pressing a touch pad. This enables the suction hoses to be disinfected either between patients or continuously throughout the treatment session.



1] The spittoon can be moved and offers easy access for both 1 or 2 assistants.

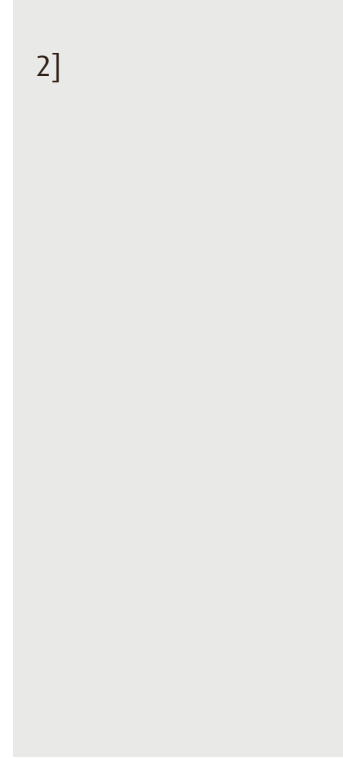

2] Integrated clean water bottle system.



3] Sterile water system, for mounting on tray adapter.



4] The spittoon bowl can be removed easily.



5] The UNIC operating light provides a natural light source with the lamp head placed on a self-balancing spring arm to ensure a stable position.

6]



8]



7]



9]



10]



6] Stable position. The double articulating neck rest improves patient positioning and is suitable for both adults and children.

7] Easy to clean. The UNIC upholstery is easy to remove for cleaning.

8] Patient comfort. The compensating movements of the backrest and seat, as well as the

integrated elbow support, ensure that the patient sits comfortably during the whole treatment.

9] The UNIC patient chair can be delivered with one or two armrests.

10] Joystick. Individual placement of up to 3 joysticks enables the dentist and their assistant to maintain ideal working postures.

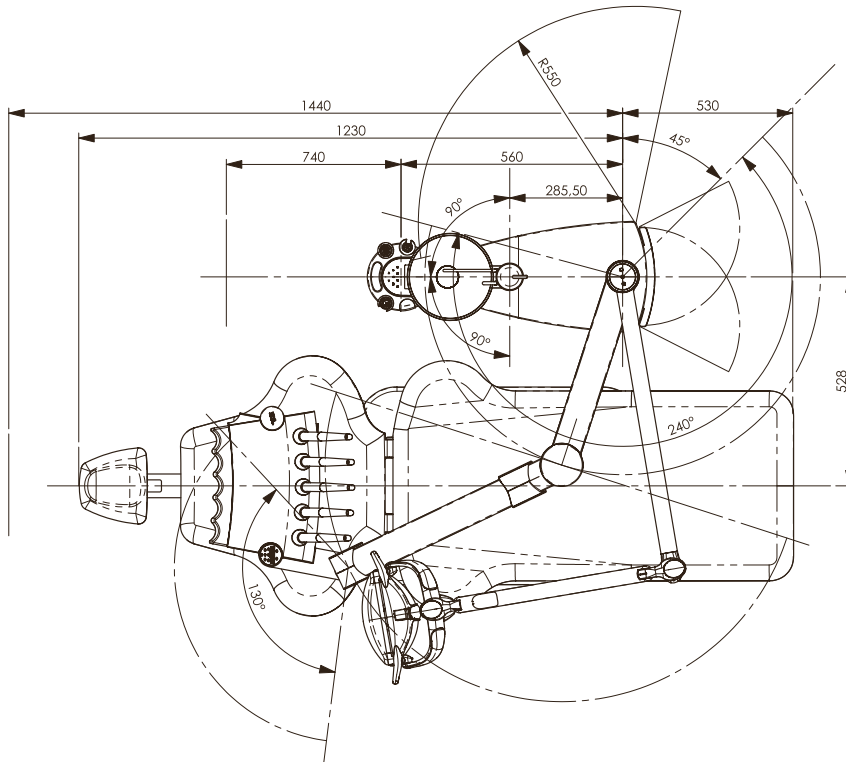
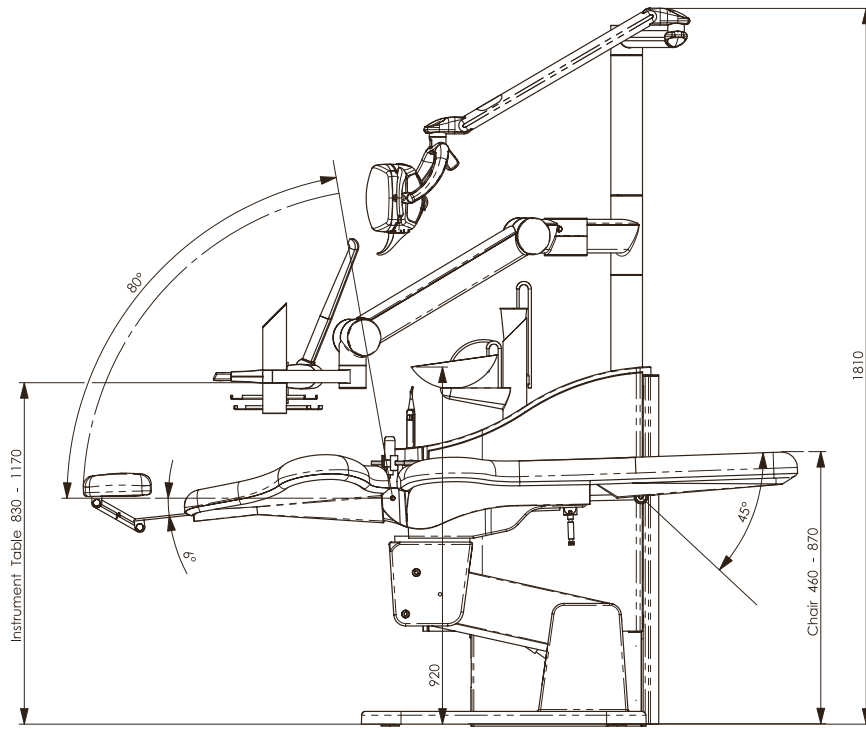

UNIC and some of its parts are design-protected, some UNIC parts are patent-protected.

Specifications

UNIC:

- Over the patient delivery system
- Side arm delivery system

Foot control:

- Standard foot control
- Variable foot control

Instruments:

- Turbine module Multiflex, fibre-optic
- Fibre-optic motor module: incl. Bien Air micro motor - 40.000 rpm
- Fibre-optic motor module: incl. Bien Air MX Brushless micro motor, incl. Digipad
- Fibre-optic motor module: incl. NSK Ti-Max micro motor - 40.000 rpm
- Syringe module: UNIC 3-function syringe
- Syringe module: Luzzani 3-function syringe
- Syringe module: Luzzani 6-function syringe
- Syringe module: Luzzani 7-function syringe with light

• Ultrasonic scaler module: Suprasson

• Ultrasonic scaler module: Piezon

• Light polymerisation module: UNIC

• Intra oral camera module, Sopro 595 and Sopro 717 excl. software

• Intra oral camera module, UNIC excl. software

• Monitor incl. lamp adapter, (s-vhs, pal and normal connection)

• Single tray

• Double tray

• X-ray monitor for mounting on tray adapter

Water treatment:

• Water supply with air gap

• Integrated water disinfection with autodosage (micro organism reduction)

• Bottle system

• Automatic water rinsing system for instruments

• Hygienic airtation, automatic (water emptied from tubes)

• Sterile water system, for mounting on tray adapter

Cuspidor:

• Manual turning

• Automatic turning

• Selective suction (2 hoses) on telescopic arm

• Selective suction (2 hoses) mounted on patient chair

• Automatic suction hose cleaner

• 3-function syringe mounted on telescopic arm: Model UNIC

• 3-function syringe mounted on telescopic arm: Model Luzzani

• 6-function syringe mounted on telescopic arm: Model Luzzani

• Light polymerisation module: UNIC 5W mounted on telescopic arm (w/button)

• Water heater for glass

• Water heater for glass and instrument table

• Quick coupling for suction

• Quick coupling for water and air

• Automatic separation: Model Dürr

• Automatic separation: Model Metasys

• Amalgam separator incl. automatic separation: Model Dürr

• Amalgam separator incl. automatic separation: Model Metasys

• Spittoon valve complete: Model Dürr

• X-ray adapter for mounting X-ray on unit

• Plug for 220 volt mounted on unit

• UNIC EDI operating light 25000 lux, 5000 Kelvin

• UNIC EDI operating light 25000 lux, 5000 Kelvin with sensor

UNIC Patient Chair

34

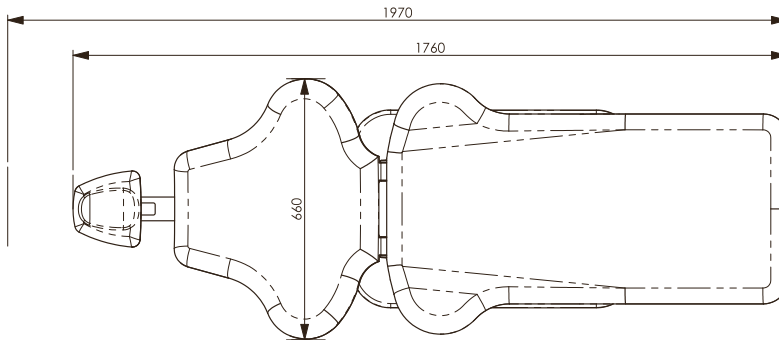
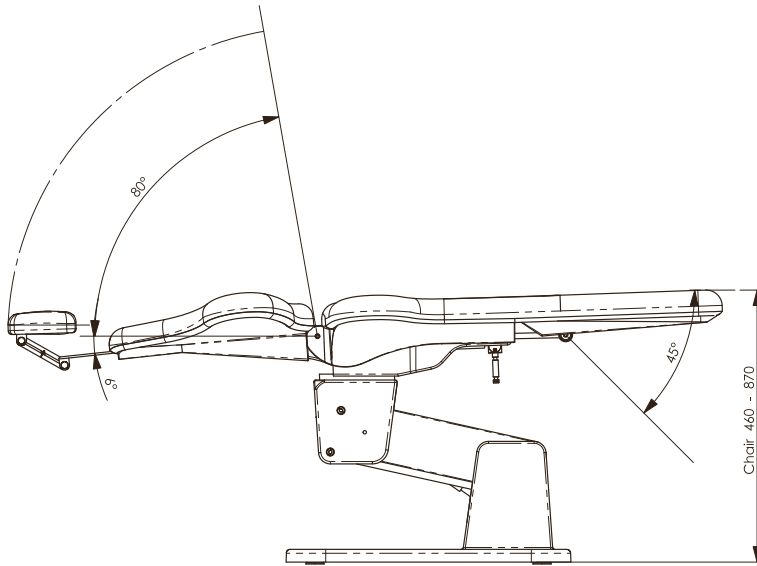

UNIC and some of its parts are design-protected, some UNIC parts are patent-protected.

Specifications

UNIC Patient Chair:

- 2 electric motors
- Maximum person weight 240 kg
- Running weight 140 kg

- Double adjustment headrest
- Extra Foot Joystick

- Patient chair with 4 programs
- Patient chair with 3 programs + last position

Upholstery:

- Soft Polster
- SuperSoft Polster

Armrest:

- Right
- Left

Upholstery colours

458 Soft	460 Soft	35
459 Soft	693 Soft	
349 Soft	348 Soft	
451 Soft	358 Soft	
351 Soft		
1107 SuperSoft	1108 SuperSoft	
1105 SuperSoft	1102 Supersoft	

heka dental

Heka Dental A/S have supplied units to dentists, the world over, since 1965 and are now a leading supplier of units in Scandinavia.

It is a family-run business with all its production, development and administration centralized in Denmark. All phases of the operation are ISO-certified which ensures high quality in all areas.

Heka Dental adapts quality and design to the individual demands made by our customers. To ensure each dentist receives the best possible guidance and information, the delivery, installation and servicing is taken care of by an extensive and well-trained network of agents.

You are always welcome to visit us or contact us with any questions or ideas.



Heka Dental A/S
Baldershøj 38
DK-2635 Ishøj, Denmark
Telefon +45 43 32 09 90
Fax +45 43 32 09 80
mail@heka-dental.dk
www.heka-dental.com

heka*dental*[®]

