

DENTAL CHAIR  
**PROGRES**

**OPERATING  
INSTRUCTIONS**

**IMPORTANT**

**This manual provides operating instructions for BELMONT PROGRES. The instructions contained in this booklet should be thoroughly read and understood before operating chair. After the installation is completed, file this manual and refer back to it for future maintenance.**

 **Belmont**





## TABLE OF CONTENTS

	Page
1. OVERALL VIEW AND MAJOR PARTS-----	1
2. DIMENSIONS AND SPECIFICATIONS-----	2A
3. OPERATING INSTRUCTIONS	
3-1. MAIN SWITCH-----	3
3-2. CONTROLS -----	3
3-3. SAFETY LOCK DEVICE -----	4A
3-4. CHAIR ROTATION -----	4A
3-5. HEADREST OPERATIONS -----	4A
4. AUTO MODE POSITION ADJUSTMENTS-----	5A
5. CARE AND MAINTENANCE-----	5A
6. ELECTROMAGNETIC COMPATIBILITY(EMC) -----	6

### Intended Use of the Product

This product is intended for the exclusive use for diagnoses, treatments and relative procedures of dentistry, and must be operated or handled by the qualified dentists or by dental staffs under the supervision of the dentist.

Such dentists or dental staffs should instruct and/or assist the patients to approach to and leave from the product.

Patients should not be allowed to operate or handle the product unless he/she is so instructed.

### Environmental Requirements

Ambient Temperature	Operating +5 °C - +40 °C	Storage -10 °C - +50 °C
Humidity	10 % - 80%	
Atmospherical Pressure	600 hPa - 1060 hPa	

### Important Notes

In case of the troubles, please contact Takara Belmont offices or your dealers.

Do not disassemble or attempt to repair.

Disassembly, repair or modifications should only be done by a qualified repair technician.

Attempts at disassembly, repair or modifications may lead to abnormal operation and accidents.

# 1. OVERALL VIEW AND MAJOR PARTS

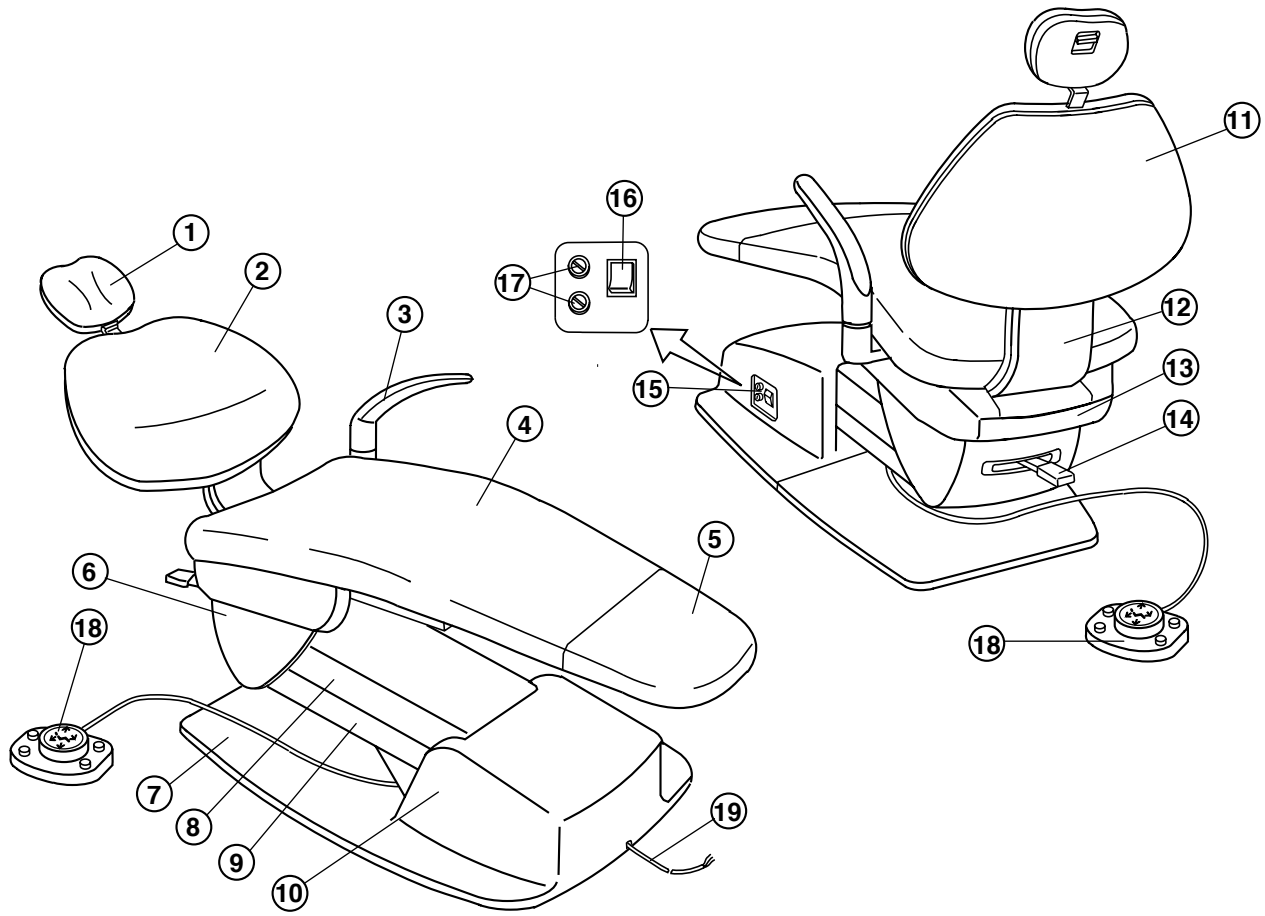

**Fig.1-1** Overall View

- |                    |                       |
|--------------------|-----------------------|
| ① Headrest         | ⑪ Backrest Cover      |
| ② Backrest         | ⑫ Back Support        |
| ③ Armrest (Left)   | ⑬ Rear Flange Cover   |
| ④ Seat             | ⑭ Rotation Lock Lever |
| ⑤ Seat Cover       | ⑮ Main Switch Panel   |
| ⑥ Flange Cover     | ⑯ Main Switch         |
| ⑦ Base             | ⑰ Fuse Holder         |
| ⑧ Upper Link Cover | ⑱ Foot Switch         |
| ⑨ Lower Link Cover |                       |
| ⑩ Pump Cover       |                       |

## 2. DIMENSIONS AND SPECIFICATIONS

### 2-1. DIMENSIONS

-mm-

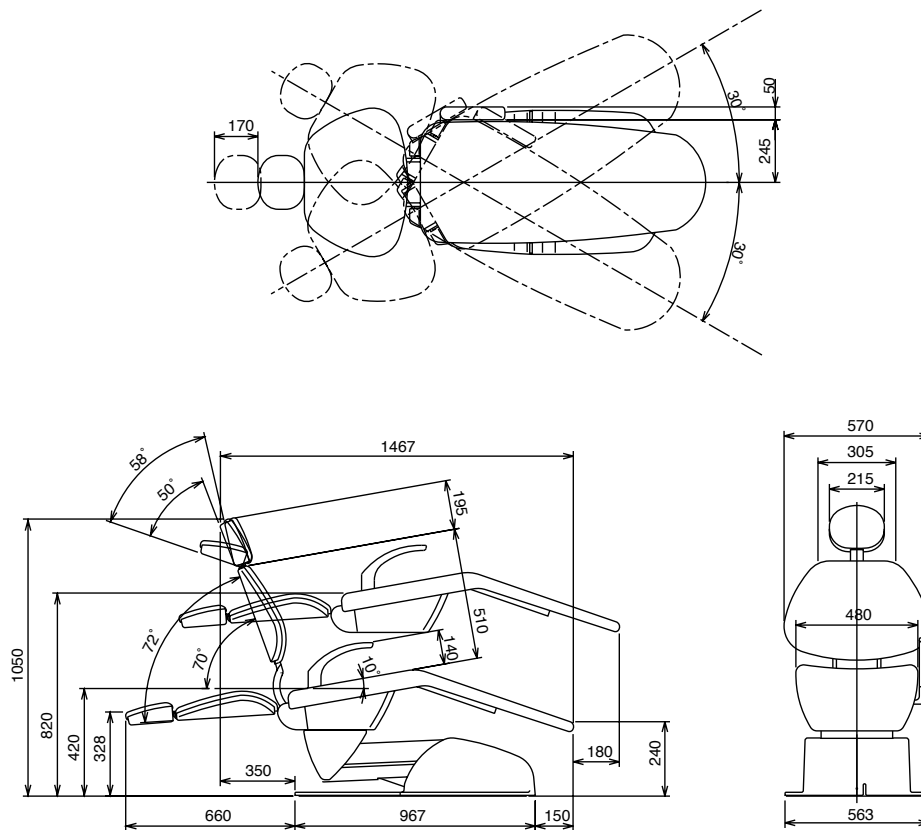

**Fig.2-1** Dimensions

### 2-2. SPECIFICATIONS

Seat Initial Height-----	420mm
Seat Lifting Stroke-----	400mm
Backrest Movement -----	-2° ~ 70° above Horizontal
Auto Movements-----	2 Preset, 1 Last Position Memory and 1 Auto Return
Control Voltage-----	DC12V
Power Consumption-----	230V, 50Hz, 2.0A
Net Weight -----	160 kg
Maximum Load -----	135 kg
Service Life-----	10 years

### 3. OPERATING INSTRUCTIONS

#### 3-1. MAIN SWITCH (Fig.1-1 & Fig.3-1)

Turn on the main switch located the left side pump cover.

A green lamp in the main switch illuminates.

#### **CAUTION**

**Operate the main switch only by hand.  
Turn off the main switch after daily operation.**

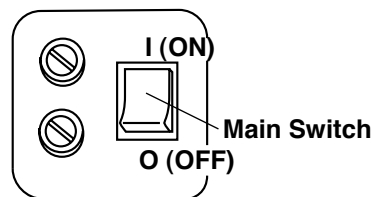

Fig.3-1 Main Switch

#### 3-2. CONTROLS (Fig.3-2)

#### **CAUTION**

**Before operating the chair, confirm safety  
for the patient and the operator.**

All chair electrical movements can be controlled by the foot switch.

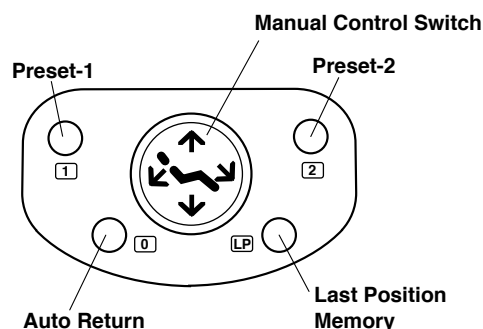

Fig.3-2 Foot Switch

#### (1) Manual Mode Control

##### A. Seat Lifting

Keep depressing (↑) side of the foot switch disc until the seat is lifted up to the desired position.

##### B. Seat Lowering

Keep depressing (↓) side of the foot switch disc until the seat is lowered to the desired position.

##### C. Backrest Reclining

Keep depressing (↙) side of the foot switch disc until the backrest is reclined to the desired position.

##### D. Backrest Raising

Keep depressing (↘) side of the foot switch disc until the backrest is raised up to the desired position.

#### (2) Auto Mode Control

##### E. Preset Control

PROGRES chair has two preset positions. (Preset-1 and Preset-2)

Momentarily depress ( 1 ) button on the foot switch, the chair will move to the preset-1 position automatically. (Preset-2 is operated by ( 2 ) button.)

##### F. Auto Return

Momentarily depress ( 0 ) button on the foot switch, the chair will return to the initial position (The seat is fully lowered and the backrest is upright position.),

##### G. Last Position Memory

Momentarily depress (LP) button at treatment position, the backrest will move to the mouth rinsing position automatically.

Momentarily depress (LP) button again, the backrest will return to the previous treatment position automatically.

## H. Emergency Stop

During automatic procedure (Preset, Auto return and Last position memory), depressing any side of disc or button on the foot switch will cancel the automatic movement immediately.

**Note :** Do not keep depressing auto mode button ( **1** )( **2** )( **0** )( **LP** ) over 3 seconds.

Memorized position in auto mode may be changed.

### 3-3. SAFETY LOCK DEVICE (Fig.3-3)

All chair movements can be stopped automatically by the safety lock device when pressure is detected between the base and the lower link cover.

In case working the safety lock device, lift up the seat and remove a cause of pressure.

**Note :** Seat lifting and backrest raising can be operated when the safety lock device is working.

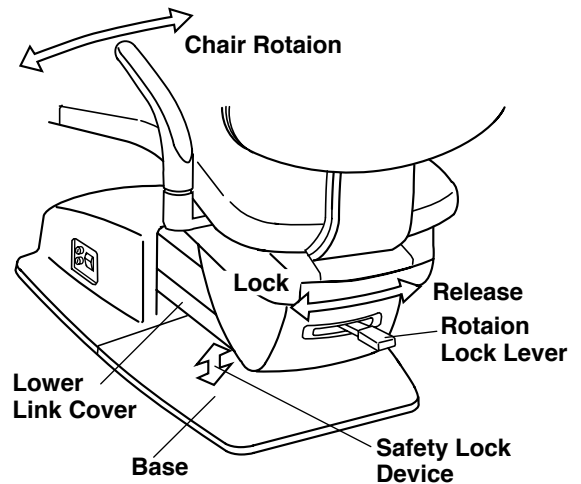

**Fig.3-3** Safety Lock Device and Chair Rotation

### 3-4. CHAIR ROTATION (Fig.3-3)

Pull the rotation lock lever to right.

The upper structure can be rotated up to 30 degrees each in right and left.

Pull the rotation lock lever to left to lock the chair.

### 3-5. HEADREST (Fig.3-4)

#### (1) Height Adjustment

Press down or pull up the headrest to the desired height.

#### (2) Angle Adjustment

Push the headrest forward as required.

Lift the headrest lever to rotate backward and release the lever at the desired angle.

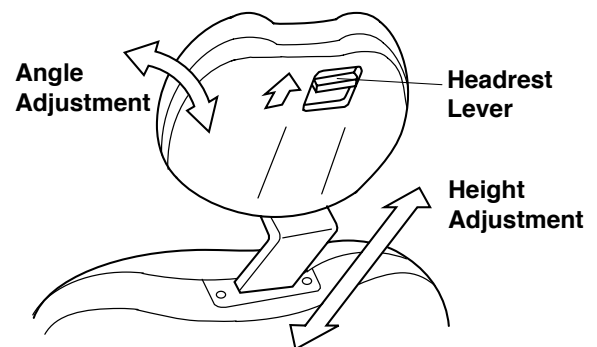

**Fig.3-4** Headrest

## ⚠ CAUTION

Support the headrest with a hand when lifting headrest lever to prevent sudden drop.

#### 4. AUTO MODE POSITION ADJUSTMENT

##### (1) Preset position Adjustment (Fig.4-1)

Two preset positions can be set.

- A. Set the seat and the backrest to the desired preset position by manual control switch.
- B. Keep depressing preset 1 switch (1) until buzzer sounds (in about 3 seconds), then release it.
- C. The position is memorized for Preset-1.
- D. Preset-2 can be memorized by depressing preset-2 switch (2), as following A to C.

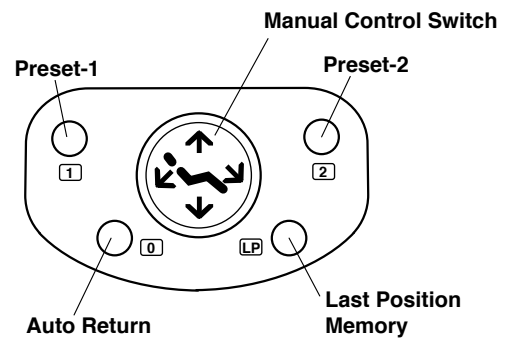

**Fig.4-1** Foot Switch

##### (2) Mouth Rinsing Position Adjustment (Fig.4-1)

Mouth rinsing position in last position memory movement can be adjusted.

- A. Set the backrest to the desired mouth rinsing position by manual control switch.
- B. Keep depressing last position memory switch (LP) until buzzer sounds (in about 3 seconds) and release it.
- C. This backrest position is then memorized as the mouth rinsing position.

#### 5. CARE AND MAINTENANCE

Other than cleaning, no scheduled maintenance of the chair is required.

#### **⚠ CAUTION**

Turn OFF the main switch at the lowest seat position after daily operation and for a long term interval.

#### **⚠ CAUTION**

All surfaces can be cleaned with DURR FD333 cleaner ( or equivalent).  
Spray the cleaner (DURR FD333) on cloth and wipe the surfaces with the cloth.  
Do not drench the chair and unit.  
Wipe all surfaces dry after cleaning.



## 6. ELECTROMAGNETIC COMPATIBILITY(EMC)

Medical electrical equipment needs special precautions regarding EMC and needs to be installed and put into service according to the EMC information provided in this manual.

Portable and mobile RF communications equipment can affect medical electrical equipment.

The equipment or system should not be used adjacent to or stacked with other equipment. If adjacent or stacked use is necessary, the equipment or system should be observed to verify normal operation in the configuration in which it will be used.

<b>Guidance and manufacture's declaration - electromagnetic emissions</b>		
The PROGRES is intended for use in the electromagnetic environment specified below. The customer or the user of the PROGRES should assure that it is used in such an environment.		
<b>Emissions test</b>	<b>Compliance</b>	<b>Electromagnetic environment - guidance</b>
RF emissions CISPR 11	Group 1	The PROGRES uses RF energy only for its internal function. Therefore, its RF emissions are very low and are not likely to cause any interference in nearby electronic equipment.
RF emissions CISPR 11	Class B	The PROGRES is suitable for use in all establishments, including domestic establishments and those directly connected to the public low-voltage power supply network that supplies buildings used for domestic purposes.
Harmonic emissions IEC 61000-3-2	Class A	
Voltage fluctuations/ Flicker emissions IEC 61000-3-3	Complies	

<b>Guidance and manufacture's declaration – electromagnetic immunity</b>			
The PROGRES is intended for use in the electromagnetic environment specified below. The customer or the user of the PROGRES should assure that it is used in such an environment.			
<b>Immunity test</b>	<b>IEC 60601 test level</b>	<b>Compliance level</b>	<b>Electromagnetic environment - guidance</b>
Electrostatic discharge (ESD) IEC 61000-4-2	±6 kV contact ±8 kV air	±6 kV contact ±8 kV air	Floors should be wood, concrete or ceramic tile. If floors are covered with synthetic material, the relative humidity should be at least 30%.
Electrical fast transient/burst IEC 61000-4-4	±2 kV for power supply lines ±1 kV for input/output lines	±2 kV for power supply lines ±1 kV for input/output lines	Mains power quality should be that of a typical commercial or hospital environment.
Surge IEC 61000-4-5	±1 kV differential mode ±2 kV common mode	±1 kV differential mode ±2 kV common mode	Mains power quality should be that of a typical commercial or hospital environment.
Voltage dips, short interruptions and voltage variations on power supply input lines IEC 61000-4-11	<5% $U_T$ (>95% dip in $U_T$ ) for 0.5 cycle 40% $U_T$ (60% dip in $U_T$ ) for 5 cycle 70% $U_T$ (30% dip in $U_T$ ) for 25cycle <5% $U_T$ (>95% dip in $U_T$ ) for 5 s	<5% $U_T$ (>95% dip in $U_T$ ) for 0.5 cycle 40% $U_T$ (60% dip in $U_T$ ) for 5 cycle 70% $U_T$ (30% dip in $U_T$ ) for 25cycle <5% $U_T$ (>95% dip in $U_T$ ) for 5 s	Mains power quality should be that of a typical commercial or hospital environment. If the user of the PROGRES requires continued operation during power mains interruptions, it is recommended that the PROGRES be powered from an uninterruptible power supply or a battery.
Power frequency (50/60 Hz) magnetic field IEC 61000-4-8	3 A/m	3 A/m	Power frequency magnetic fields should be at levels characteristic of a typical location in a typical commercial or hospital environment.
NOTE $U_T$ is the a.c. mains voltage prior to applications of the test level.			

### Guidance and manufacture's declaration - electromagnetic immunity

The PROGRES is intended for use in the electromagnetic environment specified below. The customer or the user of the PROGRES should assure that it is used in such an environment.

Immunity test	IEC 60601 test level	Compliance level	Electromagnetic environment - guidance
Conducted RF IEC 61000-4-6	3 Vrms 150 kHz to 80 MHz outside ISM bands <sup>a</sup>	3 Vrms	<p>Portable and mobile RF communications equipment should be used no closer to any part of the PROGRES, including cables, than the recommended separation distance calculated from the equation applications to the Frequency of the transmitter.</p> <p><b>Recommended separation distance</b>  <math>d = 1.2\sqrt{P}</math></p>
Radiated RF IEC 61000-4-3	3V/m 80 MHz to 2.5 GHz	3 V/m	<p><math>d = 1.2\sqrt{P}</math> 80 MHz to 800 MHz  <math>d = 2.3\sqrt{P}</math> 800 MHz to 2.5 GHz</p> <p>Where <math>P</math> is the maximum output power rating of the transmitter in watts (W) according to the transmitter manufacturer and <math>d</math> is the recommended separation distance in metres (m).</p> <p>Field strengths from fixed RF transmitters, as determined by an electromagnetic site survey,<sup>a</sup> should be less than the compliance level in each frequency range.<sup>b</sup></p> <p>Interference may occur in the vicinity of equipment marked with the following symbol:</p> <div style="text-align: center;">  </div>

NOTE 1 At 80 MHz and 800MHz, the higher frequency range applies.

NOTE 2 These guidelines may not apply in all situations. Electromagnetic propagation is affected by adsorption and reflection from structures, objects and people.

- a Field strengths from fixed transmitters, such as base stations for radio (cellular/cordless) telephones and land mobile radios, amateur radio, AM and FM radio broadcast and TV broadcast cannot be predicted theoretically with accuracy. To assess the electromagnetic environment due to fixed RF transmitters, an electromagnetic site survey should be considered. If the measured field strength in the location in which the PROGRES is used exceeds the applicable RF compliance level above, the PROGRES should be observed to verify normal operation. If abnormal performance is observed, additional measures may be necessary, such as reorienting or relocating the PROGRES.
- b Over the frequency range 150 kHz to 80 MHz, field strengths should be less than 3V/m.

#### Essential performance (purpose of IMMUNITY testing)

Unless operated by the switches for chair control, the PROGRES does not make any movements, except for sounding a buzzer and switching on/off the indicator.

**Recommended separation distances between  
Portable and mobile RF communications equipment and the PROGRES**

The PROGRES is intended for use in an electromagnetic environment in which radiated RF disturbances are controlled. The customer or the user of the PROGRES can help prevent electromagnetic interference by maintaining a minimum distance between portable and mobile RF communications equipment (transmitters) and the PROGRES as recommended below, according to the maximum output power of the communications equipment.

Rated maximum output power of transmitter W	Separation distance according to frequency of transmitter m		
	150 kHz to 80 MHz $d = 1.2 \sqrt{P}$	80 MHz to 800 MHz $d = 1.2 \sqrt{P}$	800 MHz to 2.5 GHz $d = 2.3 \sqrt{P}$
0.01	0.12	0.12	0.23
0.1	0.38	0.38	0.73
1	1.2	1.2	2.3
10	3.8	3.8	7.3
100	12	12	23

For transmitters rated at a maximum output power not listed above, the recommended separation distance  $d$  in metres (m) can be estimated using the equation applicable to the frequency of the transmitter, where  $P$  is the maximum output power rating of the transmitter in watts (W) according to the transmitter manufacturer.

NOTE 1 At 80 MHz and 800MHz, the separation distance for the higher frequency range applies.

NOTE 2 These guidelines may not apply in all situations. Electromagnetic propagation is affected by adsorption and reflection from structures, objects and people.

# NOTE



**Takara Belmont (UK) Ltd.**

Bemont House  
One St.Andrews Way, Bow,  
London E3 3PA U.K.  
Tel : (44) 20-7515-0333  
Fax : (44)20-7987-3596



BOOK NO. AEFT04E0  
Printed in Japan 0903